

MARK "S" OR "SPS"
ALSO MARK STAINLESS
MATERIAL WITH A "C"
LOCATION OPTIONAL
AS SHOWN. MULTIPLE
MARKING PERMITTED

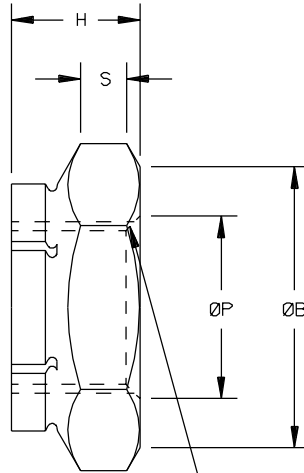

STYLE A

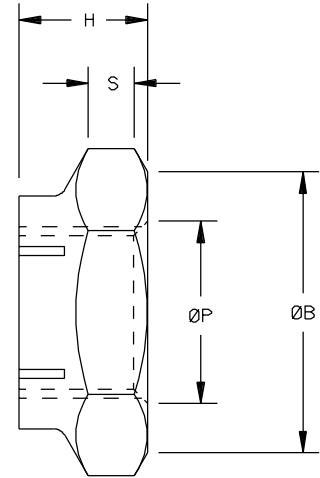

STYLE B

COUNTERSINK, COUNTERBORE OR RADIUS RELIEF
TO THREADS WITHIN THE LIMITS OF ØP

EITHER STYLE TO BE SUPPLIED AT SPS' OPTION

TYPE	DASH NUMBER	THREADS SEE NOTE 5	ØB MIN	C MIN	H MAX	ØP MAX	S MIN	W		AXIAL STRENGTH LBS MIN			WEIGHT APPROX LBS/100
								MAX	MIN	STEEL AND STAINLESS	ALUMINUM	BRASS	
FKC	420	.250-20 UNC-2B	.492	.552	.219	.293	.053	.502	.492	4,450	2,290	1,960	.80
FK	518	.312-18 UNC-2B	.553	.623	.266	.356	.087	.564	.553	4,980	3,030	2,590	1.25
FK	616	.375-16 UNC-2B	.616	.694	.282	.418	.085	.627	.616	7,360	3,890	3,330	1.55
FK	714	.437-14 UNC-2B	.741	.836	.328	.487	.101	.752	.741	10,100	5,290	4,530	2.59
FK	813	.500-13 UNC-2B	.803	.907	.328	.551	.101	.814	.803	11,400	6,480	5,550	2.83
FKC	912	.562-12 UNC-2B	.928	1.049	.368	.614	.104	.940	.928	14,600	10,060	8,620	4.28
FK	1011	.625-11 UNC-2B	.990	1.121	.399	.676	.116	1.002	.990	18,100	10,700	9,170	5.13
FK	1210	.750-10 UNC-2B	1.115	1.263	.415	.807	.121	1.127	1.115	26,800	13,100	11,200	6.62
FK	1409	.875-9 UNC-2B	1.301	1.476	.477	.938	.163	1.314	1.301	36,940	20,400	17,500	11.90
FK	1608	1.000-8 UNC-2B	1.489	1.690	.571	1.064	.207	1.502	1.489	48,500	26,800	22,970	18.71
FK	1807	1.125-7 UNC-2B	1.801	2.046	.634	1.191	.202	1.814	1.801	61,100	27,100	23,200	27.90
FK	2007	1.250-7 UNC-2B	1.988	2.259	.759	1.315	.287	2.002	1.988	77,600	34,500	29,600	44.97
FK	2206	1.375-6 UNC-2B	2.176	2.473	.818	1.440	.300	2.190	2.176	79,700	35,400	30,300	51.85
FK	2406	1.500-6 UNC-2B	2.363	2.688	.884	1.565	.326	2.377	2.363	96,900	43,000	36,800	65.33

INFORMATION ON THIS DOCUMENT IS A TRADE SECRET, PROPRIETARY, AND SHALL NOT BE USED OR REPRODUCED IN WHOLE OR IN PART WITHOUT WRITTEN AUTHORIZATION OF SPS TECHNOLOGIES.

TOLERANCES ±.010 AND ±2"
SURFACE ROUGHNESS 125
UNLESS OTHERWISE NOTED
DRAWN BY: STEVE FOSTER
APPROVED: M ZATAVESKI
APPROVED: M LAWLER

THIS
PRODUCT DRAWING
IS DRAFTED
IN ACCORDANCE
WITH ASME Y14.5M
DATE: 7/29/91
DATE: 4/28/2000



FSCM NO. 56878
CUSTODIAN:
JENKINTOWN, PA.

STANDARDS AND SPECIFICATIONS
NASM25027
AS APPLICABLE

TITLE
NUT, FLEXLOC, THIN, HEAVY DUTY SERIES,
SELF-LOCKING

PART NUMBER: **FK & FKC**
SHEET 1 OF 2

1. MATERIAL: STEEL, CARBON.
 STAINLESS STEEL, AUSTENITIC.
 316 STAINLESS STEEL, AUSTENITIC.
 BRASS, NAVAL HALF HARD.
 ALUMINUM, 2024-T4 OR 2024-T351.
 PLAIN, (CARBON STEEL NUTS WILL BE SUPPLIED WITH RUST PREVENTATIVE OIL, AND
 STAINLESS STEEL NUTS WILL BE PASSIVATED)
2. FINISH: CADMIUM PLATE PER QQ-P-416, TYPE I, CLASS 2. (CARBON STEEL AND BRASS ONLY)
 CADMIUM PLATE PER QQ-P-416, TYPE II, CLASS 2. (CARBON STEEL AND BRASS ONLY)
 DULL NICKEL PLATE PER AMS 2403 (CARBON STEEL ONLY)
 SILVER PLATE PER AMS 2410. (STAINLESS STEEL ONLY)
 ZINC PLATE PER ASTM B633, TYPE DEFINED BY FINISH CODE MODIFIER, Fe/Zn 5. (CARBON STEEL ONLY)
 ANODIZE PER MIL-A-8625. (ALUMINUM ONLY).
3. LUBRICANT: UNLESS OTHERWISE SPECIFIED, PARTS SHALL BE SUPPLIED WITH A NON-DRY LUBRICANT (WAX TYPE),
 AND WHEN SPECIFIED, MOLYBDENUM DISULFIDE DRY FILM LUBRICANT.
4. THREADS: BEFORE LUBRICATION PER MIL-S-7742, CLASS 2B.
5. LOCKING TORQUE PER NASM25027 AS APPLICABLE. EXCEPT REUSABILITY NOT REQUIRED ON UNPLATED STAINLESS
 STEEL NUTS AND LIMITED TO 5 REUSE CYCLES ON UNPLATED, DRY FILM LUBRICATED, STAINLESS STEEL NUTS.
6. DISCONTINUITIES PER NASM25027.
7. DIMENSIONS SHALL BE MET PRIOR TO LUBRICATION ON DRY FILM LUBRICATED NUTS.
8. DIMENSIONS ARE IN INCHES.
9. BREAK SHARP EDGES.
10. SURFACE TEXTURE PER ANSI B46.1 SHALL NOT EXCEED 125 MICROINCHES UNLESS OTHERWISE SPECIFIED.
11. USAGE LIMITATIONS: THESE NUTS ARE DESIGNED TO BE USED ON EXTERNAL THREADS WITHIN THE LIMITATIONS
 OF MS33588.
12. PART NUMBERING SYSTEM:

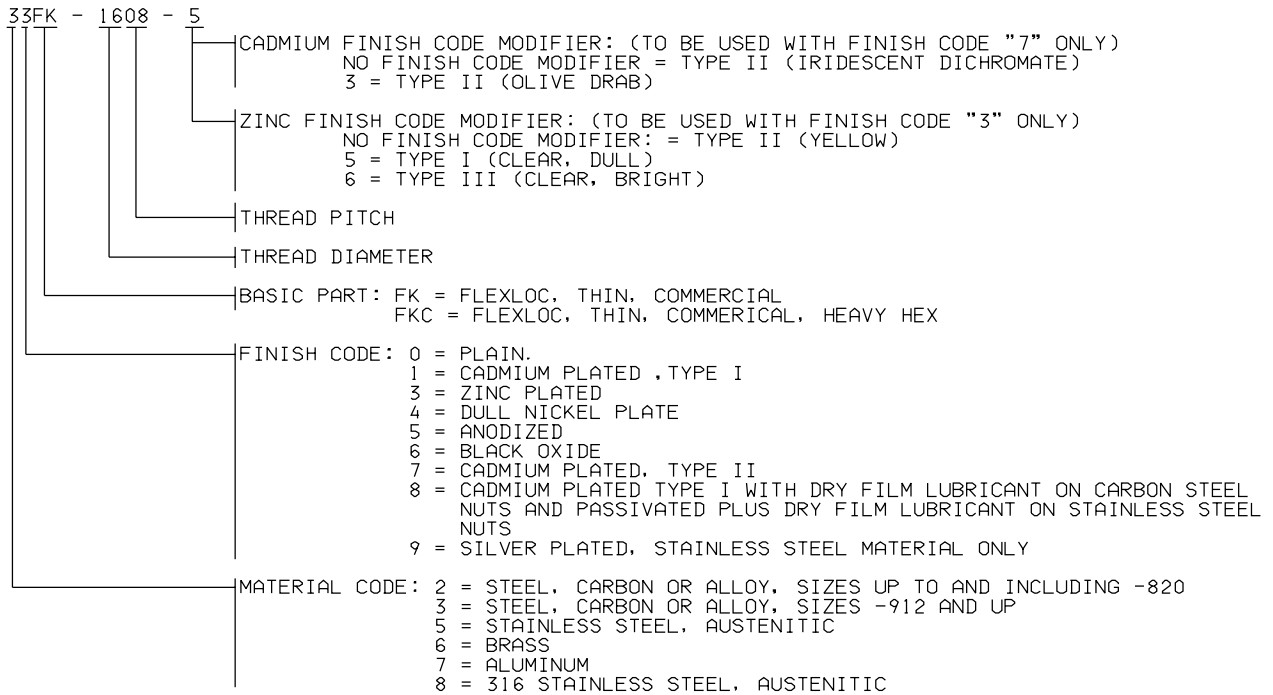

EXAMPLES: 33FK-1608-5 = 1.000 DIAMETER, THIN, SELF-LOCKING FLEXLOC MADE FROM CARBON STEEL WITH ZINC
 PLATE PER ASTM B633, TYPE I (CLEAR, DULL), Fe/Zn5.

59FKC-2406 = 1.500 DIAMETER, THIN, HEAVY HEX, SELF-LOCKING FLEXLOC MADE FROM STAINLESS STEEL
 WITH SILVER PLATE PER AMS 2410.